

Safetygram #16

Safe Handling of Cryogenic Liquids

Introduction

A cryogenic liquid is defined as a liquid with a normal boiling point below -240°F (-150°C). The most commonly used industrial gases that are transported, handled, and stored in the liquid state at cryogenic temperatures are argon, helium, hydrogen, nitrogen, and oxygen.

There are a number of general precautions and safe practices that must be observed because of the extremely low temperatures and high rates of conversion into gas of for all the cryogenic liquids. There are also specific precautions that must be followed where a particular liquid may react with contaminants or may present other hazards associated with that particular product such as asphyxiation or flammability.

The user of any cryogenic liquid covered in this Safetygram should be familiar with both the general and specific precautions outlined. Safetygrams for individual cryogenic liquids are available and should be consulted for additional information. Please consult www.airproducts.com/productsafety to determine which Safetygrams may be of assistance. As always, end users should have and be thoroughly familiar with the Material Safety Data Sheet (MSDS) for their specific product. All operators must be familiar with the instructions provided with the equipment to be used with the cryogenic liquid.

General Safety Precautions

For products covered in this Safetygram, many of the same safety precautions apply whether the product is in the gas or liquid state. Each cryogenic liquid has its own unique properties. Potential hazards stem from the following common properties:

1. All cryogenic liquids are extremely cold. Cryogenic liquids and their vapors can rapidly freeze human tissue and can cause many common materials such as carbon steel, rubber, and plastics to become brittle or even break under stress. Cryogenic liquids in containers and piping at temperatures at or below the boiling point of liquefied air [-318°F (-194°C)] can actually condense the surrounding air and can cause a localized oxygen-enriched atmosphere. Extremely cold cryogenics such as hydrogen and helium can even freeze or solidify the surrounding air.
2. All cryogenic liquids produce large volumes of gas when they vaporize. For example, one volume of liquid nitrogen vaporizes to 694 volumes of nitrogen gas at 68°F (20°C) at 1 atm. A cryogenic liquid cannot be indefinitely maintained as a liquid even in well-insulated containers. If these liquids are vaporized in a sealed container, they can produce enormous pressures that could rupture the container. For this reason pressurized cryogenic containers are normally protected with multiple devices for over-pressure prevention. Common pressure-relief devices are a pressure-relief valve for primary protection and a rupture disc for secondary protection. All sections of equipment that may allow for the liquid to become trapped must be protected by a pressure-relief device as shown in Figure 1. The product vented by these relief devices should be routed to a safe outdoor location.

Figure 1

Use of Pressure Relief Device to help prevent over-pressurization due to vaporization of trapped liquid.

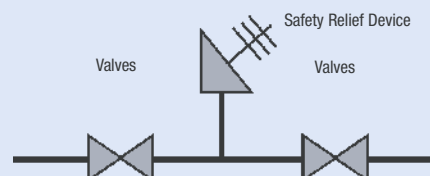

3. Vaporization of a cryogenic liquid, except oxygen, in an enclosed area can cause asphyxiation by displacing the air. Vaporization of liquid oxygen in an enclosed area can cause oxygen enrichment which could saturate combustibles in the area such as workers' clothing. This can cause a fire if an ignition source is present. Although oxygen is not flammable it will support and vigorously accelerate the combustion of other materials.

Most cryogenic liquids are odorless, colorless, and tasteless when vaporized into the gaseous state. Most liquids also have no color except liquid oxygen, which is light blue. However, extremely cold liquids and their vapors have a built-in warning property that appears whenever they are exposed to the atmosphere. The cold "boil-off" gases condense the moisture in the surrounding air, creating a highly visible fog. This fog can also be formed around cold equipment when no release of the cold liquid or vapors has occurred.

Fog clouds do not define the vapor cloud. They define the area where the vapors are still cold enough to condense the moisture in the air. The vapors can extend well beyond the fog cloud, depending on the product and atmospheric conditions. Although fog clouds may be indicative of a release, they must never be used to define the leak area and should not be entered by anyone. The dense fog clouds associated with the handling or transfer of cryogenic liquids can obstruct visibility. Care should be exercised so that any clouds do not interfere with vehicle traffic or safety escape routes.

Handling

Always handle cryogenic liquids carefully. Their extremely low temperatures can produce cryogenic burns of the skin and freeze underlying tissue. When spilled on a surface, they tend to spread as far as the quantity of liquid spilled and the physical confines of the area permit. They can cool large areas. The vapors coming from these liquids are also extremely cold and can produce burns.

Exposure to these cold gases, which is too brief to affect the skin of the face or hands, may affect delicate tissues, such as the eyes. Stand clear of boiling and splashing liquid and the cold vapors that are released. Boiling and splashing always occur when charging a warm container or when inserting objects into the liquid. Always perform these operations slowly to minimize the splashing and boiling. Never allow any unprotected part of your body to touch uninsulated pipes or vessels containing cryogenic liquids. The extremely cold material may stick fast to skin and tear the flesh when you attempt to withdraw it. Even nonmetallic materials are dangerous to touch at these low temperatures.

Use tongs to immerse and remove objects from cryogenic liquids. In addition to the hazards of frostbite or flesh sticking to cold materials, objects that are soft and pliable at room temperature, such as rubber or plastics, are easily broken because they turn brittle at low temperatures and may break when stressed.

Personal Protective Equipment

Personnel must be thoroughly familiar with the properties and safety considerations before being allowed to handle a cryogenic liquid and its associated equipment.

The eyes are the most sensitive body part to the extreme cold of the liquid and vapors of cryogenic liquids. The recommended personal protective equipment for handling cryogenics includes a full faceshield over safety glasses, loose-fitting thermal insulated or leather gloves, long-sleeved shirts, and trousers without cuffs. In addition, safety shoes are recommended for people involved in the handling of containers. Depending on the application, special clothing suitable for that application may be advisable.

A special note on insulated gloves: Gloves should be loose-fitting so they are able to be quickly removed if cryogenic liquid is spilled on them. Insulated gloves are not made to permit the hands to be put into a cryogenic liquid. They will only provide short-term protection from accidental contact with the liquid.

In emergency situations, self-contained breathing apparatus (SCBA) may be required.

Special Inert Gas Precautions

The potential for asphyxiation must be recognized when handling inert cryogenic liquids. Because of the high expansion ratios of cryogenic liquids, air can quickly be displaced. Oxygen monitors are recommended whenever cryogenic liquids are handled in enclosed areas. People should not be permitted in atmospheres containing less than 19.5% oxygen without supplied air.

Liquid helium has the potential to solidify air, which can block pressure-relief devices and other container openings. This can result in pressure buildup that may rupture the container.

Special Oxygen Precautions

Do not permit smoking or open flames in any areas where liquid oxygen is stored or handled. Do not permit liquid oxygen or oxygen-enriched air to come in contact with organic materials or flammable or combustible substances of any kind. Some of the organic materials that can react violently with oxygen when ignited by a spark or even a mechanical shock are oil, grease, asphalt, kerosene, cloth, tar, and dirt that may contain oil or grease. If liquid oxygen spills on asphalt or other surfaces contaminated with combustibles, do not walk on or roll equipment over the spill area. Keep sources of ignition away for 30 minutes after all frost or fog has disappeared.

Any clothing that has been splashed or soaked with liquid oxygen or exposed to high oxygen concentrations should preferably be removed immediately and aired for at least an hour. Personnel should stay in a well-ventilated area and avoid any source of ignition until their clothing is completely free of any excess oxygen. Clothing saturated with oxygen is readily ignitable and will burn vigorously.

Special Hydrogen Precautions

Do not permit smoking or open flames in any area where liquid hydrogen is stored or handled. All major stationary equipment should be properly grounded. All electrical equipment and wiring should be in accordance with National Fire Protection Association Pamphlet 50B and/or National Electrical Code, Article 500. Boil-off gas from closed liquid hydrogen containers used or stored inside buildings must be vented to a safe location.

Liquid hydrogen should not be poured from one container to another, or transferred in an atmosphere of air. If this is done, the oxygen in the air will condense in the liquid hydrogen, presenting a possible explosion hazard. Liquid hydrogen also has the potential of solidifying air which can block safety relief devices and other openings, which may lead to rupture of the container. Dewars and other containers made of glass are not recommended for liquid hydrogen service. Breakage makes the possibility of explosion too hazardous to risk.

Every effort must be made to avoid spills, regardless of the rate of ventilation, because it is impossible to avoid creating a flammable vapor cloud.

Containers

Cryogenic liquids are stored, shipped, and handled in several types of containers, depending on the quantity required by the user. The types of containers in use are the dewar, cryogenic liquid cylinder, and cryogenic storage tank. Storage quantities vary from a few liters to many thousands of gallons. Since heat leak is always present, vaporization takes place continuously. Rates of vaporization vary depending on design of the container, ambient conditions, and the volume of stored product.

Containers are designed and manufactured according to the applicable codes and specifications for the temperatures and pressures involved.

Dewars

Figure 2 illustrates a typical, vacuum-jacketed dewar. A loose-fitting dust cap over the outlet of the neck tubes prevents atmospheric moisture from plugging the neck and allows gas produced from vaporized liquid to escape. This type of container is non-pressurized. The most common unit of measure for the capacity of a dewar is the liter. Five- to 200-liter dewars are available. Product may be removed from small dewars by pouring, while larger sizes will require a transfer tube. Cryogenic liquid cylinders, which are pressurized vessels, are sometimes incorrectly referred to as dewars.

Figure 2

A Typical Dewar

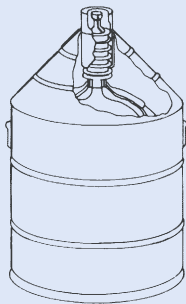

Cryogenic Liquid Cylinders

Figure 3 shows a typical cryogenic liquid cylinder. Cryogenic liquid cylinders are insulated, vacuum-jacketed, pressure vessels. They come equipped with safety relief valves and rupture disks to protect the cylinders from excessive pressure build-up. These containers operate at pressures up to 350 psig and have capacities between 80 and 450 liters of liquid.

Product may be withdrawn as a gas by passing liquid through an internal vaporizer or as a liquid under its own vapor pressure. For more details on the construction and operation of cryogenic liquid cylinders, consult Air Products' Safetygram #27, Cryogenic Liquid Containers.

Figure 3a

Typical Cryogenic Liquid Cylinder, side view

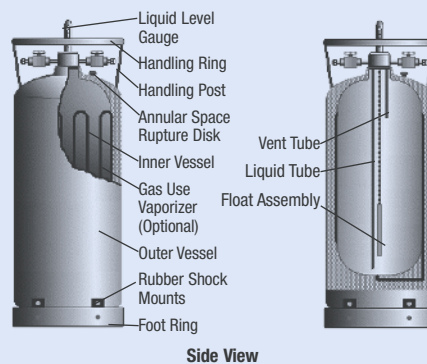

Cryogenic Storage Tanks

A typical customer installation (see Figure 4) includes a tank, vaporizer, and pressure control manifold. Tanks may be spherical or cylindrical in shape. They are mounted in fixed locations as stationary vessels or on railroad car or truck chassis for easy transportation. Sizes range from 500 gallons to 420,000 gallons. All tanks are powder- and vacuum-insulated in the annular space. Tanks are equipped with various circuits to control product fill, pressure buildup, pressure relief, product withdrawal, and tank vacuum. Tanks are designed to ASME specifications for the pressures and temperatures involved.

Figure 4

A Typical Customer Station with a Cryogenic Storage Tank

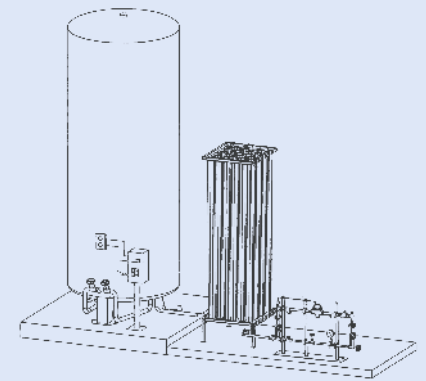
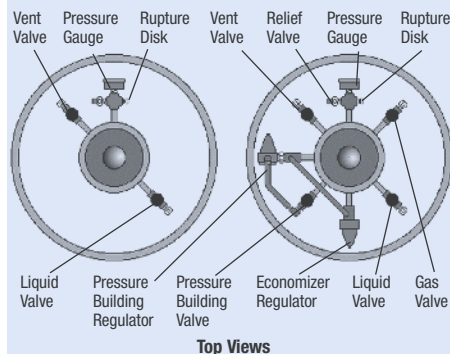

Figure 3b

Typical Cryogenic Liquid Cylinder, top view



Transfer Lines

A liquid transfer line is used to safely remove liquid product from dewars or cryogenic liquid cylinders. A typical transfer line for dewars is connected to a bayonet that provides a means of using product vapor pressure buildup or an external pressure source to remove the liquid. For cryogenic liquid cylinders, the transfer line is connected to the cylinder liquid withdrawal valve.

Liquid product is typically removed through insulated withdrawal lines to minimize the vaporization of liquid product to gas. Insulated flexible or rigid lines are used to withdraw product from storage tanks. Connections on the lines and tanks vary by manufacturer.

Liquid cylinders designed to dispense gases have valves equipped with standard Compressed Gas Association (CGA) outlets. Suitable pressure regulating equipment may be attached. Valves provided for the withdrawal of liquid product are also equipped with standard CGA outlets, but they are different than the connections used for gaseous withdrawal. This is to prevent accidental introduction of liquid into a gas system, or of gas into a liquid system.

Shipment of Cryogenic Liquids

Containers used for transporting cryogenic liquids at less than 25 psig (40 psia) pressure are not UN/DOT authorized containers. These are containers built to other than Department of Transportation (DOT) specifications but are authorized by the DOT for use in the transport of approved products. Containers used for transporting cryogenic liquids at pressures greater than 25 psig (40 psia) must be designed, manufactured, and tested to DOT specifications. For air shipments all packages must be in compliance with International Air Transport Association/International Civil Air Organization (IATA/ICAO) Dangerous Goods Regulations, as well as the DOT regulations.

Buildings

Because of the large expansion ratio of liquid to gas with cryogenic liquids, it is very important to provide adequate ventilation where cryogenic liquids are stored and used. Monitors should be available to check for oxygen concentrations in the atmosphere when working with inert cryogenics or with liquid oxygen. The minimum permissible oxygen concentration for unprotected personnel is 19.5%, while the maximum is 23.5%. In the case of liquid hydrogen, the atmosphere should be monitored with a flammable gas detector. All pressure-relief devices should be piped to safe areas, preferably outdoors.

Fighting Fires

It is not possible to outline specific fire fighting techniques that will cover all types of fires involving cryogenic liquids. Such measures depend upon the quantity and nature of the cryogenic liquid involved, the location of the fire with respect to adjacent areas and occupants, and on other factors. The following general procedures are applicable to all fires involving cryogenic liquids:

1. Everyone not actively engaged in the fighting of the fire should leave the area. If a flammable cryogenic liquid is involved, the flammable mixture zone, under unusual atmospheric conditions, may extend beyond the normal fog cloud produced by condensing water vapor in the air. People should be evacuated well outside the fog area.
2. The best fire-fighting technique is simply to shut off the flow of cryogenic liquid or vaporized gas if a flammable cryogenic liquid is involved.
3. If electrical equipment is involved in the fire, be sure the power supply is disconnected before fighting the fire with water. Or use carbon dioxide or dry chemical extinguishers.
4. When employing water, use large quantities, preferably in spray form, to cool equipment in areas surrounding the fire. Use the spray to cool any burning material below its ignition temperature. If possible, do not spray cold areas of equipment, or direct water onto the cryogenic liquid. Keep water away from vent stacks and safety relief devices that can be plugged with frozen water. Fire hoses with adjustable stream-to-spray nozzles should be available where large quantities of flammable cryogenic liquids are handled.
5. Depending upon the circumstances, it is generally not advisable to extinguish a flammable cryogenic liquid in a confined area. If the flammable gas supply cannot be shut off, the continued escape of unburned gas can create an explosive mixture in the air. The mixture may be reignited by other burning material or hot surfaces. It is usually better to allow the gas to burn itself out in a confined area and keep adjacent objects cool with water, rather than to risk a potential explosion.
6. If an inert cryogenic liquid is involved, there is the possibility of reducing the oxygen content of the air with the potential risk of asphyxiation of the fire fighters. Judgment should be used to determine which risk is greater to fire fighters—that of shutting off the supply valve, which may be in an area not easily accessible because of the fire, or the risk of an oxygen-deficient atmosphere due to the reduction of the oxygen content.

7. Oxygen, whether gaseous or liquid, is an oxidizer and does not burn, so there can be no fire unless combustible materials are also present. The difference is that the presence of additional oxygen will make combustible materials burn much faster and more violently or explosively. Shut off the oxygen supply if at all possible. Neither liquid nor gaseous oxygen can be effectively blanketed by agents such as carbon dioxide, dry chemical, or foam. It is necessary to cool combustible materials below their ignition temperatures to stop the fire. Use large quantities of water in spray form.

First Aid

For skin contact, remove any clothing that may restrict circulation to the frozen area. Do not rub frozen parts; tissue damage may result. As soon as practical, place the affected area in a warm water bath which has a temperature that does not exceed 105°F (40°C). Never use dry heat. Call a physician as soon as possible.

Frozen tissue is usually pain-free and appears waxy with a possible yellow color. It will become swollen, painful, and prone to infection when thawed. If the frozen part of the body has been thawed, cover the area with a dry sterile dressing with a large bulky protective covering, pending medical care.

In case of massive exposure, remove the victims' clothing while showering him or her with warm water. Call a physician immediately.

If the eyes are exposed to the extreme cold of the liquid or vapors, immediately warm the frostbite area with warm water not exceeding 105°F (40°C) and seek medical attention.

If the body temperature is depressed, the person must be warmed gradually. Shock may occur during the correction of hypothermia. Cardiac dysrhythmias may be associated with severe hypothermia.

Emergency Response System

- Call: +1-800-523-9374
(Continental U.S. and Puerto Rico)
- Call: +1-610-481-7711 (other locations)
- 24 hours a day, 7 days a week
- For assistance involving Air Products and Chemicals, Inc. products

Product Safety Information

- For MSDS, Safetygrams, and Product Safety Information
www.airproducts.com/productsafety

Technical Information Center

- Call: +1-800-752-1597 (U.S.)
- Call: +1-610-481-8565 (other locations)
- Monday–Friday, 8:00 a.m.–5:00 p.m. EST
- Fax: +1-610-481-8690
- E-mail: biotech@airproducts.com

Information Sources

- Compressed Gas Association (CGA)
www.cganet.com
- American Chemistry Council
www.americanchemistry.com

For More Information**Corporate Headquarters**

Air Products and Chemicals, Inc.
7201 Hamilton Boulevard
Allentown, PA 18195-1501

The accuracy or completeness of all statements, technical information and recommendations contained herein is not guaranteed and no warranty of any kind is made in respect thereto. Such statements and information are given for general use only and should not be solely relied upon by the recipient when establishing appropriate procedures for his or her own operation.

tell me more
www.airproducts.com/productsafety